

THIS DRAWING IS UNPUBLISHED
 VERTRAULICHE UNVERÖFFENTLICHTE ZEICHNUNG
 RELEASED FOR PUBLICATION
 FREI FUER VERÖFFENTLICHUNG
 24-JUL- - 2001
 MATED WITH:
 PASSEND ZU:
 LOC A1
 DIST -
 P LTR
 REVISIONS
 AENDERUNGEN
 DESCRIPTION
 BESCHREIBUNG
 DATE DWN APVD
 A1 EG00-1033-01 29MAR2001 NG GF
 A2 NOTES FOR HAND-TOOLS ADDED 10SEP2002 NG GF

© COPYRIGHT 2001 BY TYCO ELECTRONICS CORPORATION. ALL RIGHTS RESERVED.
 VERBODEN TOEGELIJKEN OF TE kopiëren. ALLE RECHTEN VOORBEHALTEN.
 onlinecomponents.com
 THE ONLINE DISTRIBUTOR OF ELECTRONIC COMPONENTS

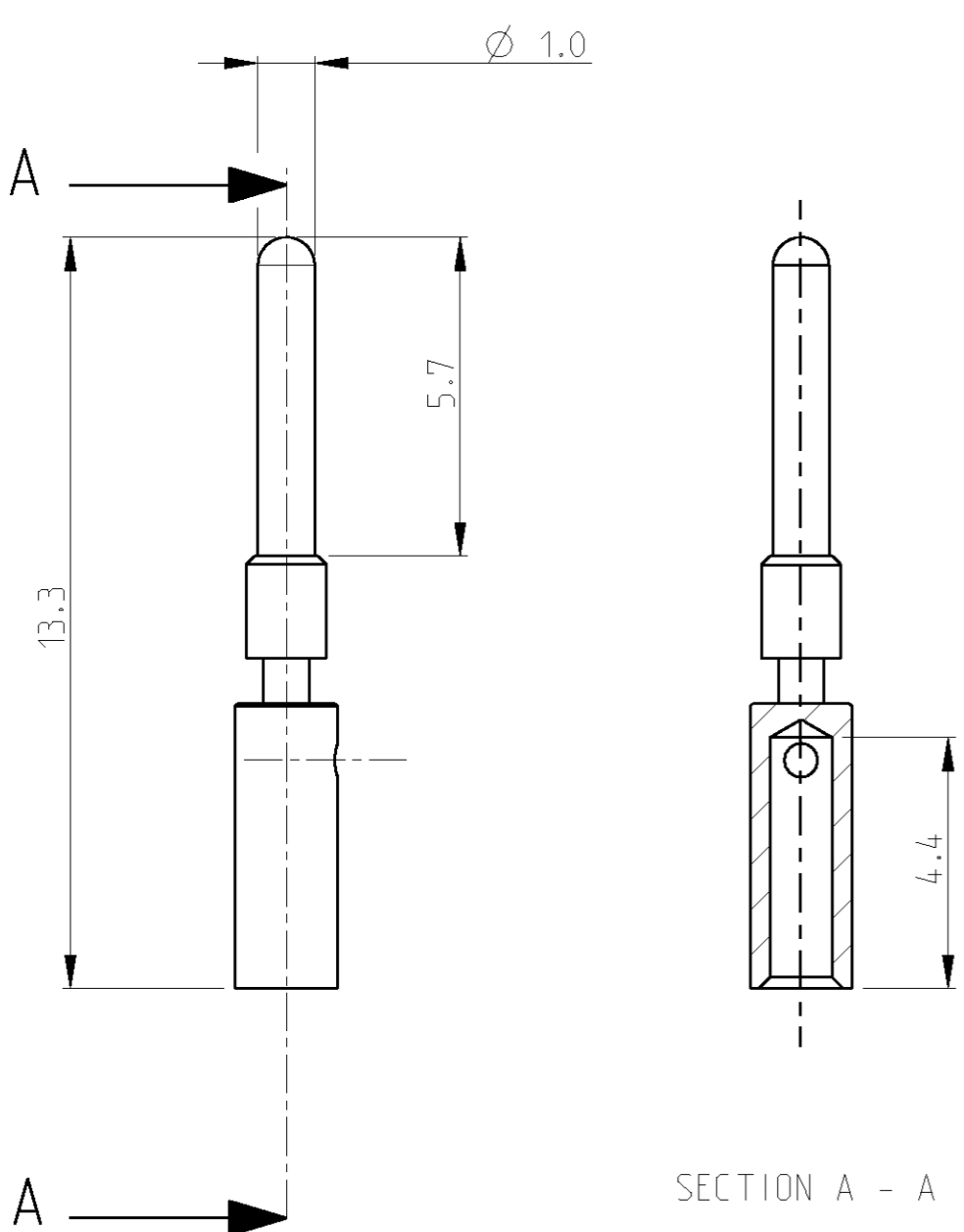

1. MATERIAL: BRASS
 MATERIAL: MESSING
 2. PLATING: TRIBOR 4 µm
 BESCHICHTUNG: TRIBOR 4 µm
- ⚠ MATING HAND-CRIMPING-TOOL SEE PN 601966-1
 USED WITH POSITIONER PN 1579003-1
 PASSENDE HANDZANGE SIEHE PN 601966-1
 IN VERBINDUNG MIT POSITIONIERER PN 1579003-1

	CONNECTING CROSS-SECTION ANSCHLUSSQUERSCHNITT	SET-NO. ON HAND-CRIMPING TOOL HANDZANGENPOSITION	
5-1437720-4	0.5mm ²	6	-
5-1437720-5	0.25mm ²	-	5
5-1437720-5	0.14mm ²	-	5

ORDER QUANTITY/ BESTELLMENGE	300 PIECES/STUECK	500 PIECES/STUECK
CATALOG-NO./ KATALOG-NR.	T01-CRIMP-P03	T01-CRIMP-P05
TYCO-NO./ TYCO-NR.	5-1437720-4	5-1437720-5

THIS DRAWING IS A CONTROLLED DOCUMENT FOR TYCO ELECTRONICS CORPORATION IT IS SUBJECT TO CHANGE AND THE CONTROLLING ENGINEERING ORGANIZATION SHOULD BE CONTACTED FOR THE LATEST REVISION. DIESES ZEICHNUNGSDOKUMENT WIRD DURCH AMP INCORPORATED KONTROLLIERT. AENDERUNGEN, DIE DEM TECHNISCHEN FORTSCHRITT DIENEN, SIND VORBEHALTEN. DEN JEW EILS LETZTIGUELTIKEN AENDERUNGSSTAND ERFAHREN SIE AUF ANFRAGE.		DWN 29MAR2001 N.GEISTER CHK 29MAR2001 H.SCHERER APVD 29MAR2001 G.FELDMEIER		tyco Electronics tyco Electronics AMP GmbH D - 64625 Bensheim	
DIMENSIONS: MASSEINHEITEN: mm		TOLERANCES UNLESS OTHERWISE SPECIFIED: ALLGEMEINTOLERANZEN		NAME T01 CRIMP CONTACT MALE T01 CRIMP KONTAKT STIFT	
		0 PLC ±0.125 m 1 PLC ± 2 PLC ± 3 PLC ± 4 PLC ± ANGLES/W INKEL ±1°		PRODUCT SPEC PRODUKTSPEZ. - APPLICATION SPEC VERARBEITUNGSSPEZ. -	
MATERIAL -		FINISH/OBERFLAECHE/FARBE -		WEIGHT GEWICHT -	
CUSTOMER DRAWING		/KUNDENZEICHNUNG		SCALE MASSSTAB -	
SIZE A3		CAGE CODE 00779		DRAWING NO ZEICHNUNGS-NR. 5-1437720-4	
SHEET BLATT 1		OF VON 1		RESTRICTED TO NUR FUER -	
REV A2					